



School of Biotechnology and Cryogenic Systems, ITMO University

People, Planet, Profit

Igor V. Baranov,
Professor, DSc.
Director

Olga N. Rumiantceva
Associate professor, Ph.D.
Deputy Director



St. Petersburg, 2021

ITMO University

✓ ITMO University participates in the national program for improving its position in the world ranking

Ranking of Times
Higher Education
501-600

QS World
University
Rankings
360

ITMO University includes 5 schools

Internet Technologies and Programming

Computer Technologies and Controls

Photonics

Biotechnology and Cryogenic Systems (SBCS)

Economics, Management and Innovations

SBCS: 90th anniversary



Igor V. Baranov,
Professor, DSc.
Director SBCS

- ✓ Saint-Petersburg State University of Refrigeration and Food Engineering became a part of the ITMO University in 2012 as the School of Biotechnology and Cryogenic Systems. University of Refrigeration and Food Engineering was founded in 1931.



In every sphere of human activity ranging from low temperature storage of agricultural products to the implementation of space projects one can find highly qualified specialists who are alumni of the School of Biotechnology and Cryogenic Systems.





Structure

**School of Biotechnology
and Cryogenic Systems**

**Faculty of
Biotechnologies**

**Faculty of
Energy and
Ecotechnology**

ChemBio Cluster



Research areas at the Faculty of Energy and Ecotechnology

- ✓ Life support, ventilation and conditioning systems;
- ✓ Engineering of low-temperature and energy systems;
- ✓ Integration and intensification of energy processes technologies;
- ✓ Structural materials for low-temperature equipment;
- ✓ Renewable energy, storage and energy storage systems;
- ✓ Technical thermodynamics and thermophysics;
- ✓ Ecology and technospheric security;
- ✓ Technologies for obtaining and transporting LNG and cryogenic gases;
- ✓ Nanotechnology and functional materials;





Research areas at the Faculty of Biotechnologies

- ✓ Theoretical and practical bases of biotechnology of multicomponent functional products for nutrition of various social and age groups;
- ✓ Efficient technologies of cold storage of agricultural raw materials and food products using additional factors to the cold;
- ✓ Development and application of new biologically active substances, enzyme and microbiological preparations in food technology;
- ✓ Technologies and equipment for the processing of new and secondary food raw materials;
- ✓ Creation of methods and tools for sustainable development of the agroindustrial complex, deep processing of secondary material resources, recycling and waste disposal;
- ✓ Research and development of technologies that ensure environmental safety in urban areas, protect natural and agro-ecosystems from anthropogenic impact;
- ✓ Development of nutrition systems, as well as technologies for the conservation of natural biodiversity and ensuring the environmental safety of environmental components in extreme climatic and biospheric conditions, including areas of the Arctic.



Research areas at ChemBio Cluster

- ✓ Nanopharmacy;
- ✓ Inkjet Printing of Functional materials;
- ✓ Computational modeling for design of functional materials;
- ✓ Ceramic and Natural Nanomaterials;
- ✓ Experimental oncology;
- ✓ Molecular Robotics and Biosensor Materials;
- ✓ Infochemistry of self-organizing systems;
- ✓ Functional Metal-organic Frameworks;
- ✓ Food Bio-Nanotechnology;
- ✓ Microbiology;
- ✓ Chemistry Education Research and Practice;

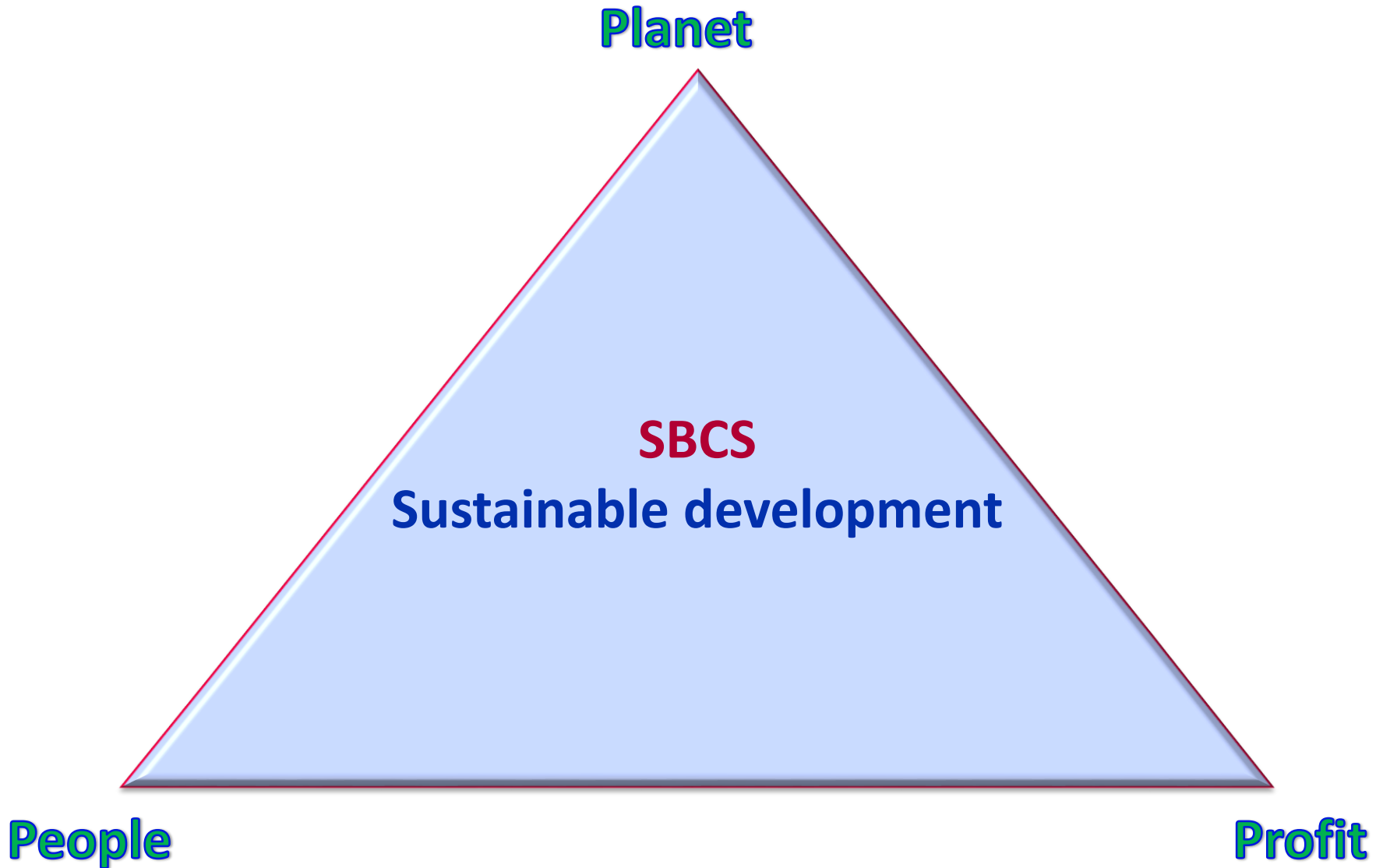

Projects of the School of Biotechnology and Cryogenic Systems

СХЕМА ВЗАИМНОЙ ИНТЕГРАЦИИ ЛОКАЛЬНОГО ЭНЕРГЕТИЧЕСКОГО УЗЛА И ИНЖЕНЕРНЫХ СИСТЕМ ЗДАНИЯ

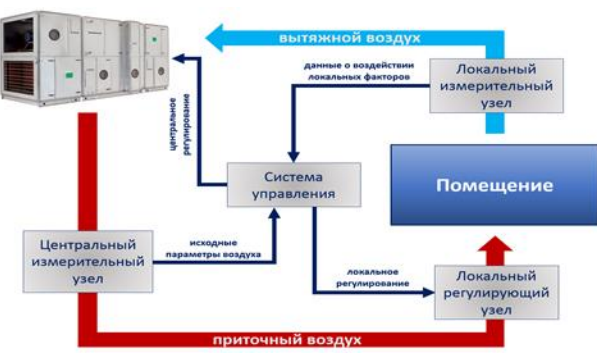
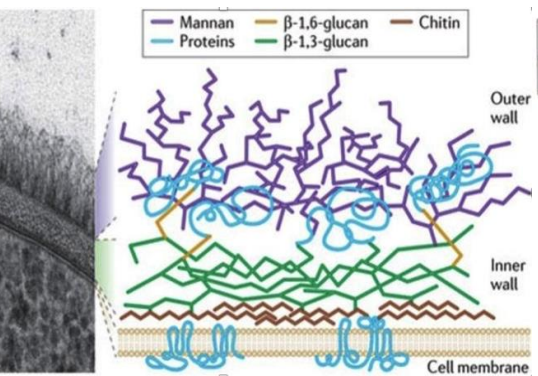
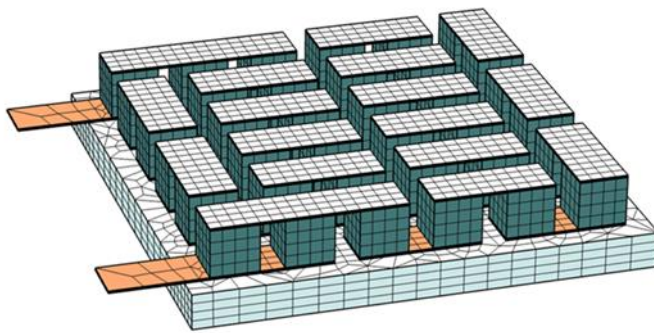
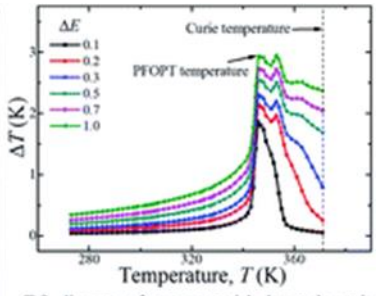
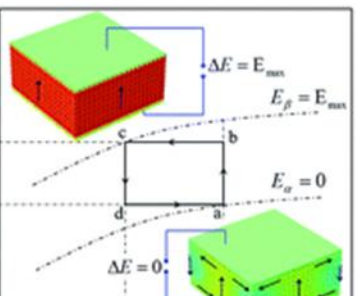
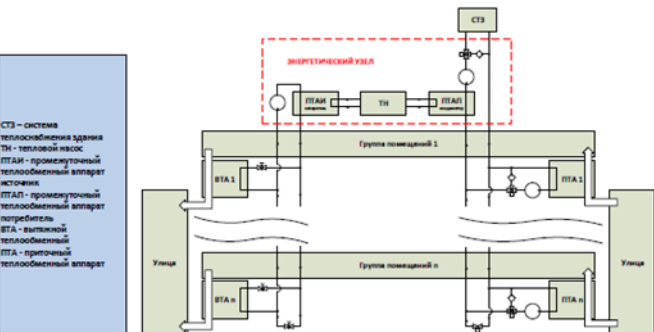

Project name: Development of a technology for mutual integration of the local Energy Hub and engineering systems of the building

Scientific advisers: Nikitin Andrei, Ph.D., andyquest@mail.ru

Muraveinikov Sergey, Ph.D., ssmuraveinikov@itmo.ru

In the public sector, ventilation and air conditioning systems are the most relevant energy consumption management. The amount of energy used to heat or cool homes is about 65% of the total energy consumption.

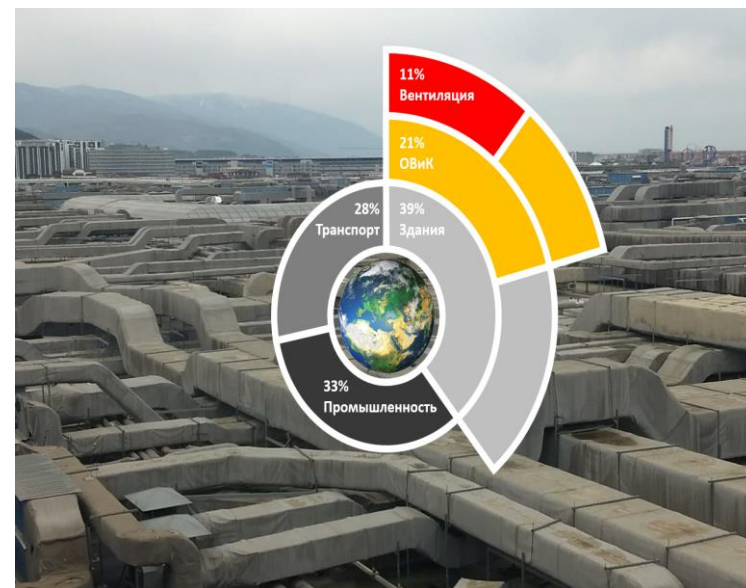

Project:

- Strategies for reducing the load in residential buildings,
- centralized control of heating, ventilation and air conditioning systems,
- introducing multi-energy hub technologies that allow redistributing energy flows among consumers,
- supplying excess energy to centralized power supply networks.

Project name: Development of a technology for mutual integration of the local Energy Hub and engineering systems of the building

Visualization of the developed system and device:

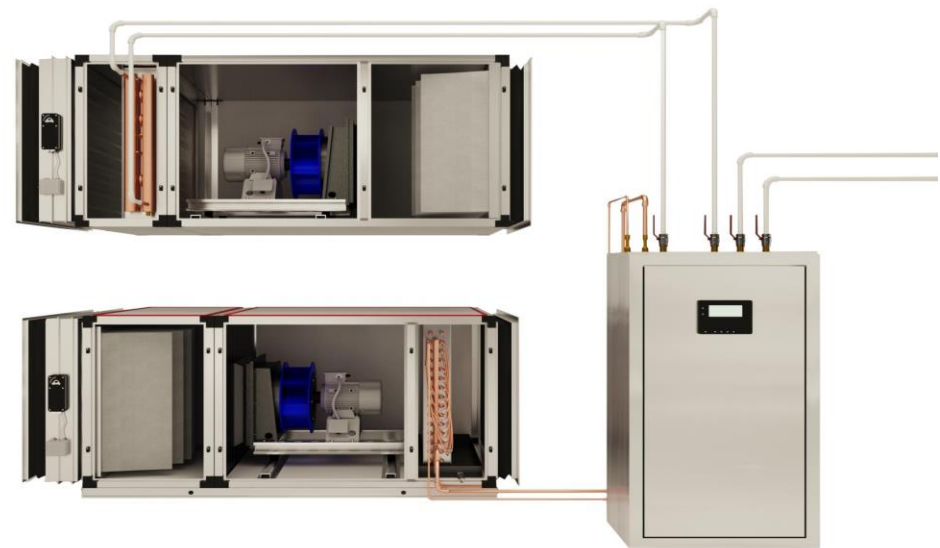

Benefits:

- reducing the consumption of heat and electricity by buildings;
- decrease in operating costs during the operation of buildings and structures.

Project name: Development of an integrated adaptive system for distributed indoor climate control

Scientific advisers: Sulin Alexander, D.Sc., miconata@rambler.ru
 Ryabova Tatyana, Ph.D., rjabova_tatjana@mail.ru

Ventilation and air conditioning systems consume up to 11% of the world's energy. Systems are not able to adapt to real conditions.

A system of adapted regulation of air parameters is proposed, which for the first time takes into account the factor of functional transformability of premises and a behavioral factor that determines the intensity and dynamic characteristics of the system.

The use of this system gives:

- complete picture of the actual loads on a particular room in real time
- provides an energy efficient mode of operation of the air conditioning system.

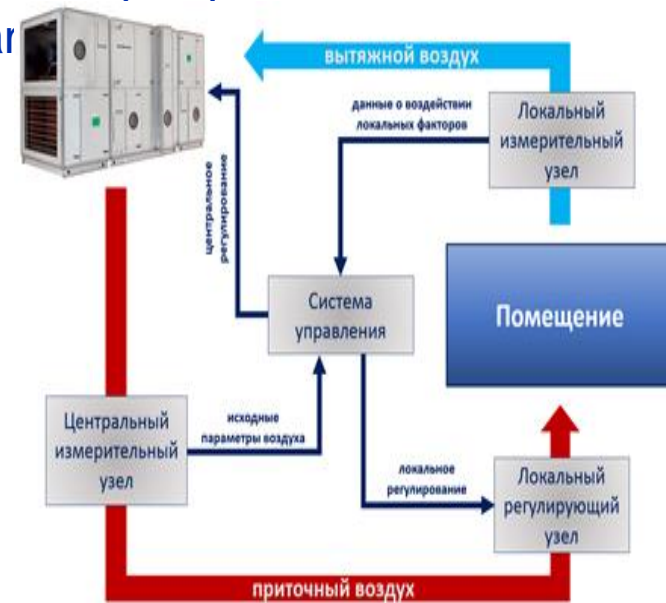

Project name: Development of an integrated adaptive system for distributed indoor climate control

Benefits:

- the adaptive system adjusts itself, taking into account the dynamics of changes in microclimate parameters;
- the operation of the adaptive control system does not depend on the room configuration;
- the system does not use sensors installed in the room.

Characteristics:

Nominal air flow rate of local units (m ³ /h)	no more than 700
Deviation of the local air flow during regulation from the nominal air flow (%)	no more than 10
The nominal value of the index of thermal comfort PMV (point)	from – 0,1 to +0,1
Deviation of the PMV thermal comfort index (score)	no more than 0,1
Reduction of energy consumption of the ventilation system from the nominal measured parameter without adaptive regulation (%)	not less than 15

Project name: Selection and substantiation of technology for changing the thermophysical parameters of liquefied natural gas to reduce losses from evaporation during its accumulation, storage and transportation

Scientific adviser: Baranov Alexander, D.Sc., abaranov@itmo.ru

Daily losses from LNG evaporation are estimated at 0.1%.

Increasing the efficiency of operation of devices for accumulation, transportation and storage of LNG by liquefying the level of losses of cryogenic products associated with the supply of heat from the environment.

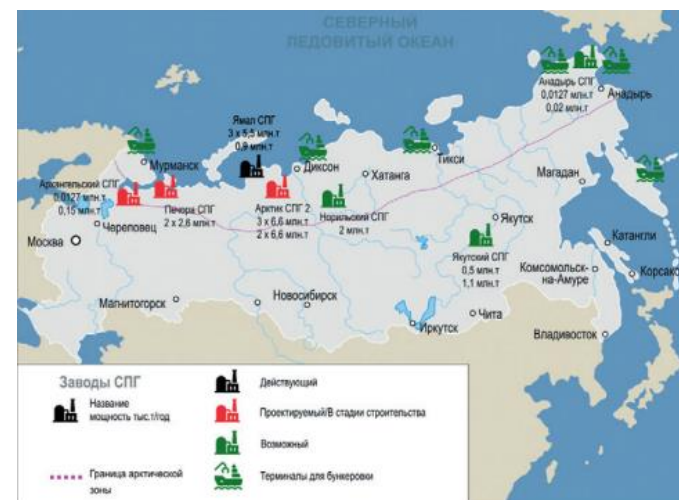

To reduce losses and increase the efficiency of the LNG production technology, it is necessary to solve a set of problems of technological and design properties.

Project name: Selection and substantiation of technology for changing the thermophysical parameters of liquefied natural gas to reduce losses from evaporation during its accumulation, storage and transportation

On the day of LNG shipment to a tanker, cryogenic tanks simultaneously contain up to 90 thousand tons of LNG → losses from evaporation are 90 tons per day. LNG is supplied to the filling terminal via a cryogenic pipeline -1 to 3 km. The pipeline is equipped with gas-filled insulation, so further evaporation of the finished product occurs in it due to the supply of heat from the insulation. The pipeline is operated periodically → significant LNG losses are associated with a decrease in the temperature of the pipeline insulation material.

Offer: to use for these purposes the introduction of LNG cooling stages.

Benefits:

- reducing LNG losses;
- increasing the profitability of liquefied natural gas production;
- reduction of environmental damage caused by emissions of LNG vapors or products of their combustion into the atmosphere;
- simplification of LNG storage and transportation processes.

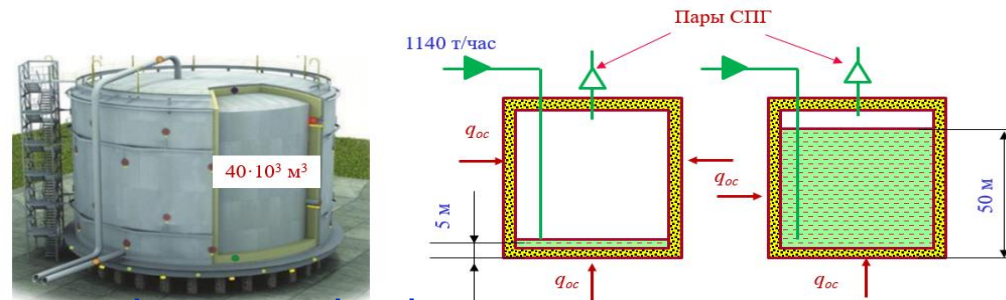

Project name: Natural Gas Liquefier Upgrade

Scientific adviser: Zaitsev Andrey, Ph.D., zai_@inbox.ru

Systematization of installations for liquefaction of natural gas (NG), promising from the point of view of increasing competitiveness due to the possibility of their improvement:

- analysis of information sources on coolants possible for use in SG liquefiers circuits;
- compiling a database;
- selection of the most promising options;
- development of a methodology for energy and exergy analysis of a liquefier in order to conduct comparative numerical experiments;
- selection of the main options for circuit and design solutions for NG liquefiers that can be improved;
- carrying out numerical experiments and processing experimental data;
- conducting a comparative energy and economic analysis;
- development of recommendations.

Project name: Natural Gas Liquefier Upgrade

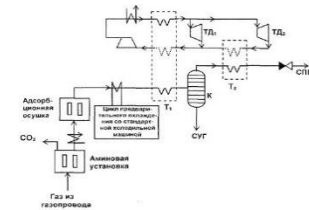
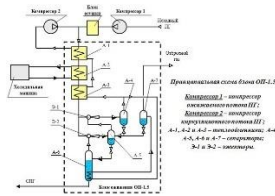
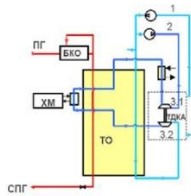

Benefits:

- reduction in the cost of LNG production;
- improving energy efficiency of natural gas liquefiers;
- utilization of low-grade heat in the production of valuable fuel;
- reduced consumption of fossil fuels;
- increasing the possibility of using waste and renewable energy sources;
- combating the problem of environmental pollution.

Project name: Mini-channel technologies in refrigeration technology

Scientific adviser: Baranenko Alexander, D.Sc., aleks.baranenko@gmail.com

A methodology has been developed for calculating local heat transfer, flow modes and pressure losses during boiling of refrigerants in evaporators of refrigeration machines with mini-channels. This methodology is based on a comprehensive analysis, including the calculation of the true vapor content, prediction of two-phase flow regimes, calculation of local heat transfer and pressure losses using the true phase velocities.

Characteristics:

Equivalent diameter	$D_h = 0,5 \dots 1,6 \text{ mm}$
Boiling temperature	$t_0 = -10 \dots +20 \text{ }^\circ\text{C}$
Mass velocity	$w_p = 110 \dots 550 \text{ kg}/(\text{m}^2 \cdot \text{s})$
Working substances refrigerants	R134a, R410

Project name: Mini-channel technologies in refrigeration technology



Experimental bench for the study of thermal and hydrodynamic processes

Benefits:

- compared to the boiling of the working substance inside the pipes:
- 2 – 2.5 times higher values of heat transfer coefficients;
- reduction of the level of filling the working substance up to 3 times;
- improved weight and size characteristics;
- increased strength and manufacturability;
- high accuracy for a wide range of geometric and operating parameters;
- optimization of operating and design parameters.

Project name: Heating and cooling systems using renewable energy sources

Scientific adviser: Baranenko Alexander, D.Sc., aleks.baranenko@gmail.com

AA system of energy saving and environmental safety has been developed based on the method of complex optimization of thermodynamic heat and cold supply systems based on absorption lithium bromide thermal transformers (ABTT) (refrigeration machines (ABRM) and heat pumps (ABHP)) using renewable energy sources.

The developed software package makes it possible to analyze the efficiency and systematization of thermodynamic cycles of various circuit solutions of absorption lithium bromide thermotransformers, depending on the parameters of external sources.

Characteristics:

Cooling capacity	100...4000 kWh
Chilled environment temperature	-5...+7°C and above
Heating capacity	230...9000 kWh
Heated environment temperature	40°C
Heating capacity	according to customer conditions
Heating environment temperature	103,5°C

Project name: Heating and cooling systems using renewable energy sources

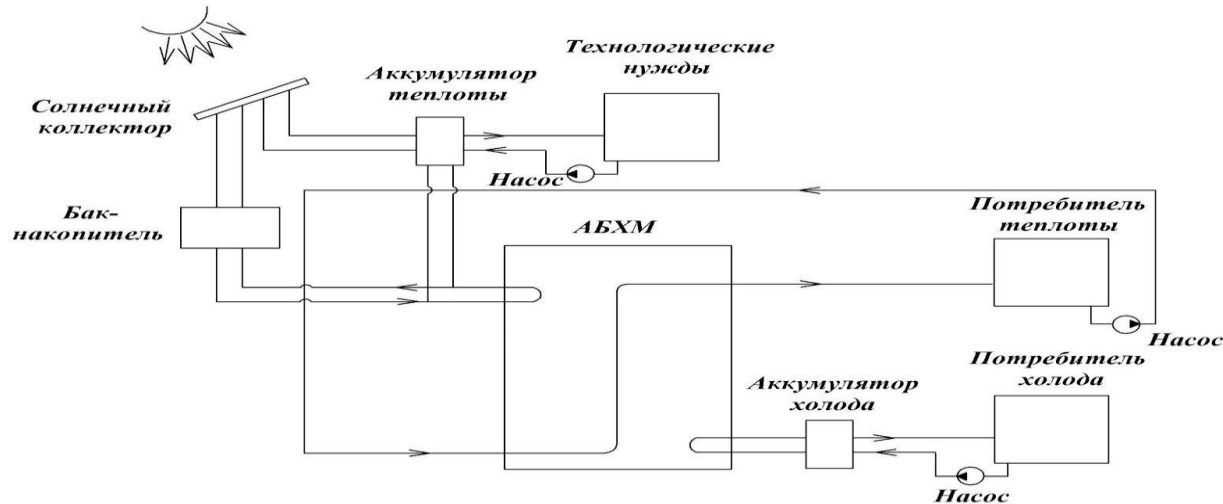

Benefits:

- provides tenfold savings in energy resources;
- allows to calculate the most optimal variant of the heat and cold supply system;
- makes it possible to select the most energy efficient ABTT unit;
- the system accumulates 8-14 times more thermal energy than batteries with a liquid medium.

Project name: Solid-state coolers and energy converters based on functional multiferroic and thermoelectric structures

Scientific adviser: Pakhomov Oleg, Ph.D., ovpakhomov@itmo.ru

A technology has been developed for creating materials and ferroelectric structures for highly efficient and environmentally friendly coolers based on electrocaloric and multicaloric effect.

Computer finite element models for prototypes of such devices have been created, topology options have been developed for creating thin-film energy converters.

Characteristics:

Cooling capacity	50...100 Wh/sm ²
Chilled environment temperature	-50...+70°C and above
Thermodynamic efficiency	80%
Heated environment temperature	40°C
Heating capacity	according to customer conditions
Heating environment temperature	20 °C and above

Project name: Solid-state coolers and energy converters based on functional multiferroic and thermoelectric structures

Caloric Effects in Multiferroic Materials

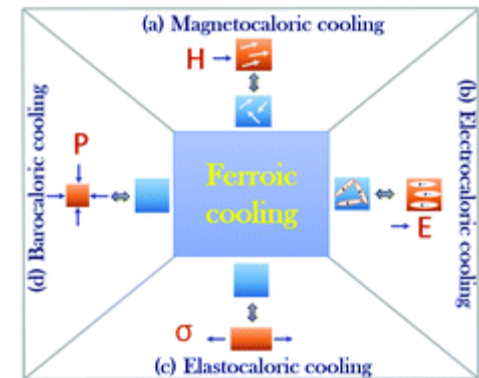

Benefits:

- provides a higher efficiency in comparison with thermoelectric modules;
- allows you to calculate the most optimal version of the system;
- environmentally friendly technology for creating materials;
- the prime cost is justified in comparison with magnetocaloric and thermoelectric modules.

Project name: Decrease in thermal conductivity in environmentally friendly thermoelectrics due to low-dimensional effects and nanostructuring

Scientific adviser: Isachenko Grigory, Ph.D., g.isachenko@itmo.ru

The project is a continuation of previous research projects devoted to the production and study of the properties of nanostructured thermoelectric materials based on silicon.

The complexity of creating effective thermoelectric materials lies in the inconsistency of the problem: it is necessary to improve (not greatly deteriorate) the electrical properties and decrease the thermal conductivity at the same time.

This problem can be solved in a special way, creating a material either in the form of a bulk (nanostructured) sample, or in the form of a low-dimensional structure (thin films, quantum dots, superlattices).

A new direction in this project is the study of the thermal conductivity of thin films and modeling the process of heat transfer in thin objects.

Project name: Decrease in thermal conductivity in environmentally friendly thermoelectrics due to low-dimensional effects and nanostructuring

Benefits:

Thermoelectric materials are the basis of thermoelectric generators (TEG). The efficiency of a TEG depends entirely on the materials used. The silicide materials studied in this project can make it possible to create thermoelectric generators with a number of advantages:

- work from any heat source;
- scalability;
- reliability;
- environmental safety;
- low weight;
- low cost.

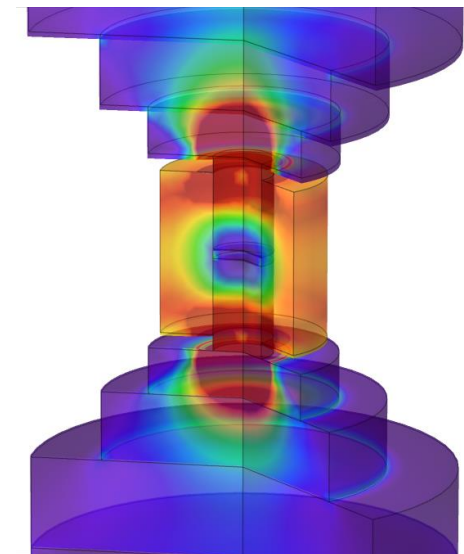

A model of a sintering plant for thermoelectric powders

Project name: Environmentally friendly technologies of energy saving and increasing the efficiency of low-temperature systems

Scientific adviser: Malinina Olga, Ph.D., holmash_malinina@mail.ru

Development of heat and cold supply systems based on absorption lithium bromide thermotransformers (ABTT) using renewable energy sources and increasing efficiency by changing design parameters in the elements of low-temperature technology and the use of ozone-safe working substances.

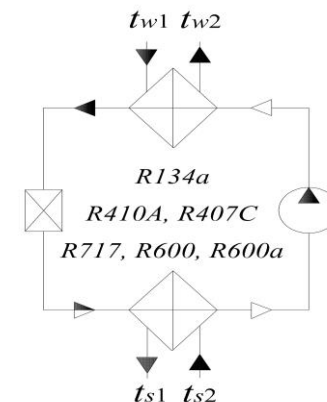

Benefits:

- allows to calculate the most optimal option of the heat and cold supply system;
- provides a reduction in carbon intensity;
- allows you to choose the most optimal option for energy-saving cooling systems for buildings;
- improved weight and size characteristics;
- increased strength and manufacturability.

Project name: Improving the efficiency of energy systems by using thermal energy storage batteries

Scientific adviser: Zakharova Victoria, Ph.D., vizakharova@itmo.ru

Improving the efficiency of heat and cold supply systems and power generating plants:

- development and use of thermal energy accumulators in them,
- the use of renewable and secondary energy resources,
- the creation of effective methods for the design of these systems. the use of substances with a phase transition (SPT) in them.

Benefits:

Advantages of thermal energy accumulators based on VFP in comparison with other types of similar devices:

- high volumetric density of stored energy due to the latent heat of the phase transition;
- constancy of temperature at which the consumption and accumulation of stored energy occurs, corresponding to the phase transition temperature.

Characteristics:

The temperature range of the phase transition is from -50°C to 400°C .

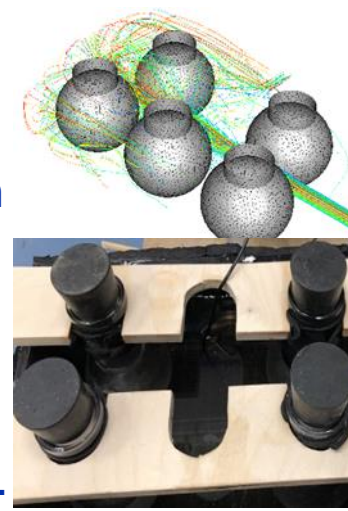

Project name: Development and research of the principles of building a digital freon analyzer

Scientific adviser: Kustikova Marina, Ph.D., makustikova@itmo.ru

Environmental and technospheric safety:

- Identification and measurement of the content of freon,
- detection of sources of supply of freon,
- assessment of the impact on climatic processes are.

Development of a method for identifying freons and for the development of an experimental sample of a freon analyzer.

The project will allow monitoring :

- the concentration of freons in confined spaces, where it is possible for people to stay for a long time;
- the maximum concentration of air in the residential area;
- the concentration of freons in rooms where it is possible to find people during the working day;
- the maximum concentration of air in the working area;
- control of leaks to the atmosphere.

Benefits:

- The use of the method of Raman spectroscopy will ensure accuracy, selectivity for the determined component, reliability and speed.

Raman Spectroscopy

Basics and Principles

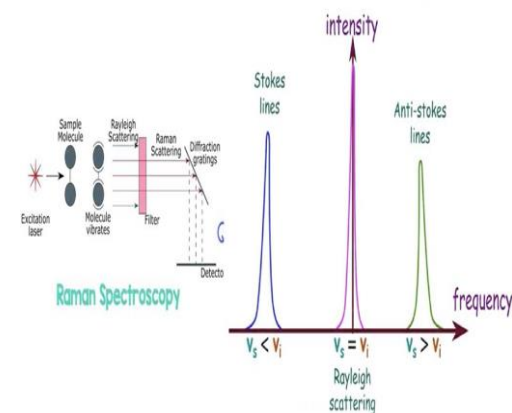

Project name: Management of municipal solid waste in St. Petersburg and the Leningrad region using micro-gas turbine technologies

Scientific adviser: Sergienko Olga, Ph.D., oisergienko@yandex.ru

One of the main problems of St. Petersburg and the Leningrad Region is the growth of MSW generation and the number of unauthorized landfills.

The annual increase in MSW is over 1.6%.

The project proposes a modular-type installation in a container, as well as the design and construction of a system that can be mobile or stationary.

The name of the saved parameters with the productivity of the thermal oxidative deactivation system for recycled waste 1000 kg / h	Unit measure ments	Combustion device type	
		Rotary kiln $\alpha = 2.0$	Layer furnace $\alpha = 1.6$
Additional fuel consumption	kg/h	190	152
Air consumption	m^3_n/h	2313	1849
The amount of generated flue gases	m^3_n/h	2482	1982
Generation of additional electrical power	kWh	222	177
Reducing the consumption of equivalent fuel in the replaced boiler houses and thermal condensing power plants	kg/h	309	242

Project name: Management of municipal solid waste in St. Petersburg and the Leningrad region using micro-gas turbine technologies

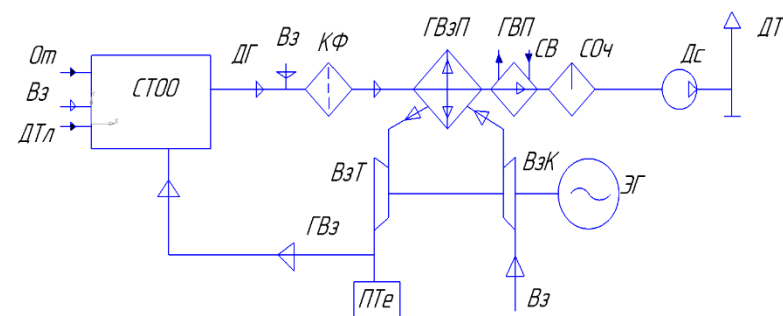

Benefits:

With the capacity of the thermo-oxidative neutralization system for the processed waste 1000 kg/h, the use of an air turbine unit for utilizing the heat of exhaust flue gases makes it possible to reduce:

- additional fuel consumption;
- consumption of air consumed;
- volume of generated flue gases, including natural ones;
- additional receipt of electrical and thermal energy;
- consumption of equivalent fuel in replaced boiler houses and thermal condensing power plants;
- contributes to the solution of the tasks of the regional operator.

Project name: Determination of the biodegradability of packaging materials under composting conditions

Scientific adviser: Molodkina Nelly, Ph.D., nrkh25@hotmail.com

Biodegradability is a potential property of a material that is biodegradable under controlled conditions, and is characterized by a set of parameters that allow a material to go through a biodegradation process to a specified stage in a specified period of time using standard test and measurement methods.

Development of a method for laboratory confirmation of biodegradability of materials.

Benefits:

- the ability to scale;
- lack of analogues;
- testing at the laboratories of ITMO University;
- compliance with foreign standards.



Project name: Obtaining secondary raw materials and energy resources based on the principles of circular economy

Scientific adviser Sergienko Olga, Ph.D., oisergienko@yandex.ru
Molodkina Nelly, Ph.D., nrkh25@hotmail.com

Effective solutions in the field of using secondary resources:

- obtaining high-humus fertilizer in the process of composting organic municipal waste;
- processing and disposal of various fractions of waste with the achievement of the effect of zero burial;
- using biological air purification from unpleasant smelling substances;
- using the skeleton of marine benthic invertebrates in the production of active calcium substances;
- using microalgae for biofuel production.

Benefits:

- Obtaining organic compost, purified from heavy metals.
- Utilization of gaseous decomposition products of organic substances using biological methods
- Obtaining bioethanol from invasive plant species and waste biomass of microalgae from treatment systems
- Development of resource-saving technology for deep processing of aquatic organisms with high calcium content



Project name: Technology of ecological rehabilitation of the environment in aquaculture by wastewater treatment

Scientific adviser: Elena Kuprina, D.Sc, elkuprina@yandex.ru

Processing any protein-containing waste, incl. from fish processing and crustacean processing to obtain food protein concentrate, mineral precipitate (bones, shell, fiber) and fat.

The effect of extracting nutrients from raw materials is achieved due to the combined action of low concentrations of e / x synthesized ions and the polarizing action of an electric field on the cell walls.
environment.

Benefits:

- simultaneity of ongoing processes in one structure;
- the use of low-consumption anodes in relation to oil (in analogs, wear-out, clogging the environment or expensive anodes are used);



Project name: Biomonitoring and control of chemical contamination of wild food products

Scientific adviser: Sergienko Olga, Ph.D., oisergienko@yandex.ru

The technology of biomonitoring of blueberries, lingonberries, cranberries assess the safety of using forest berry products in the food and pharmaceutical industries: 

- choosing the necessary parameters for controlling chemical contamination wild berries
- assessing the need to expand the range of controlled parameters, in particular, establishing maximum permissible concentrations for chromium and nickel due to their significant bioaccumulation in berries.

Content of heavy metals was carried out using the X-ray fluorescence method: strontium, lead, zinc, copper, vanadium, chromium, as well as oxides of iron, titanium and manganese.

Benefits:

- obtaining an integrated assessment of the impact of a complex of
- monitoring of the state of forests;
- the ability to recognize early symptoms of ecosystem disturbance;
- low cost of research.



Project name: Biotechnology of low-temperature storage using gas-selective membranes

Scientific adviser: Elena Kiprushkina, D.Sc, kipelena@yandex.ru

Biotechnology for creating a subnormal gas environment using gas-selective membranes:

- to preserve the nutritional value of fruits more effectively,
- to reduce their losses,
- increase the duration of their refrigerated storage.

Benefits:

- maximum preservation of the nutritional and biological value of fruits and vegetables;
- reduction of loss from microbial spoilage and loss of weight;
- an increase in the duration of refrigerated storage of fruits by 1-2 months, depending on the variety and respiration rate of the fruits.



Project name: Application of biological means of protection within the production of agricultural crops

Scientific adviser: Elena Kiprushkina, D.Sc, kipelena@yandex.ru

Treatment of potato tubers before laying for long-term storage with a suspension of the culture liquid (CL) of bacteria of the genus *Mycobacterium* is most effective and reduces the incidence of tuber fusarium and late blight by 2-3 times

Treatment of potatoes before planting with a culture liquid of bacteria-antagonists of the studied strains reduces the number of infected tubers and, consequently, yield losses by 17%. Per one ton of potato it gives economic savings of 3,4 ths rub.

Benefits:

biological treatment of potato tubers within the supply chain confirmed its economic and ecological effectiveness due to decrease of potato losses and positive impact at the nutrition value and quality of the product at the consumption stage:

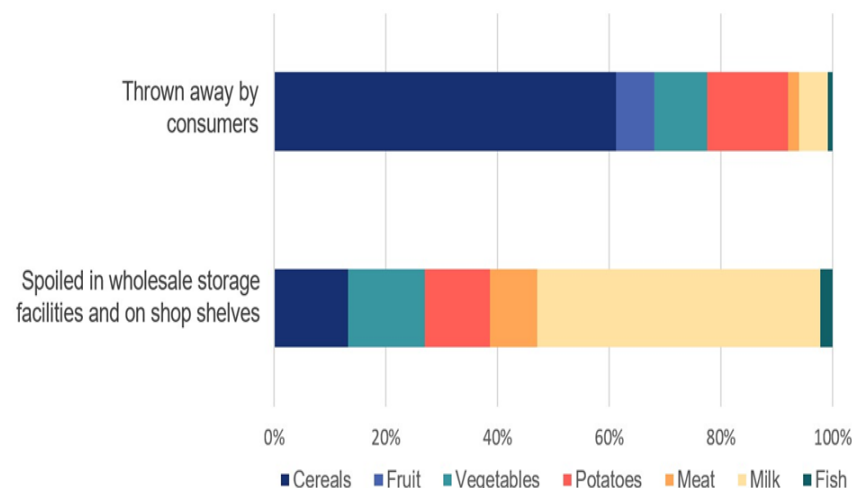

Project name: Natural immunostimulating additives in beekeeping, their effect on the survival of bees and the quality of honey

Scientific adviser: Elena Kiprushkina, D. Sc., kipelena@yandex.ru

- Mass death of bees - "collapse of bee colonies" (Colony Collapse Disorder or the Syndrome of destruction of the bee swarm) around the world.
- Beekeepers use antibiotics to treat bee diseases → wax, honey and other beekeeping products accumulate their decay products, subsequently saturating honey with them.
- Mass death of bees will lead to a decrease in yield - by 80-95%.

An immunostimulating feed additive based on beta-glucans has been created.

Benefits:

Immunomodulatory supplements:

- do not affect the quality and safety of honey;
- reduce and prevent the resistance of pathogens to antibiotics;
- reduce the content of antibiotics in honey.



Project name: Processing of hogweed to obtain useful chemical compounds

Scientific adviser: Barakova Nadezhda, Ph.D., n.barakova@mail.ru

Sosnovsky hogweed is a promising and profitable raw material for biofuel production and can replace agricultural crops used for these purposes, such as sugar beets and wheat.

The developed technology makes it possible to isolate cellulose from plant material. It can be hydrolyzed to monomers to give alcohol, or left as the final product.

Benefits:

- optimization of collection and disposal of hogweed;
- creation of fuel from new raw materials;
- low costs in the production of pulp.



Project name: Technology for processing waste from cutting aquatic organisms to obtain valuable biologically active substances

Scientific adviser: Elena Kuprina, D.Sc, elkuprina@yandex.ru

In Russia, more than 4.7 million tons of aquatic organisms are harvested and raised in aquaculture per year: fish, crustaceans, molluscs, algae. Their processing produces 35-50% of fish waste, up to 75% of crustaceans. This is 1.7 million tons, 70% of them have negative value and pollute the environment.

The proposed technology not only solves this problem, but also makes it possible to obtain products with high added value - biologically active substances: protein, including collagen, fat enriched with omega-3 acids, mineral precipitate and dietary fiber, sorbent - chitin.

Benefits:

- reagentlessness;
- lack of drains;
- the complexity of processing;
- gentle extraction conditions;
- mobility.



Project name: Development of an Insect Based Absorption Agent (LuciaCesar)

Scientific adviser: Nadtochiy Lyudmila, Ph.D., l.tochka@mail.ru

A new type of natural fiber has been developed in the form of a chitin-melanin complex based on papules of the larvae of the green meat fly (LuciaCesar).

In the market for chitosan and its derivatives, there are limitations associated with the cultivation of aquatic organisms, which affect the development of the chitosan market.

Important: to search and development of alternative methods for the production of chitosan and its derivatives from non-aqueous sources

Benefits:

- consists of natural fiber;
- generated on the waste of the closed-loop cultivation of the green meat fly (LuciaCesar);
- has a low cost.



Project name: The role of biologically active substances of natural origin in the development and nutritional prevention of non-communicable diseases

Scientific adviser: Baranenko Denis, Ph.D., denis.baranenko@itmo.ru

Nutrition is one of the main risk factors for the development of noncommunicable diseases such as diabetes mellitus, cancer, cardiovascular, chronic respiratory and age-related neurodegenerative diseases.

Raw materials for obtaining a wide range of protective biologically active substances can be plant materials in which many functional metabolites have been identified.

Benefits:

- no additional technological equipment is required;
- to produce inexpensive and effective functional products of a new generation, equally accessible to both residents of megalopolises and hard-to-reach regions of the country.

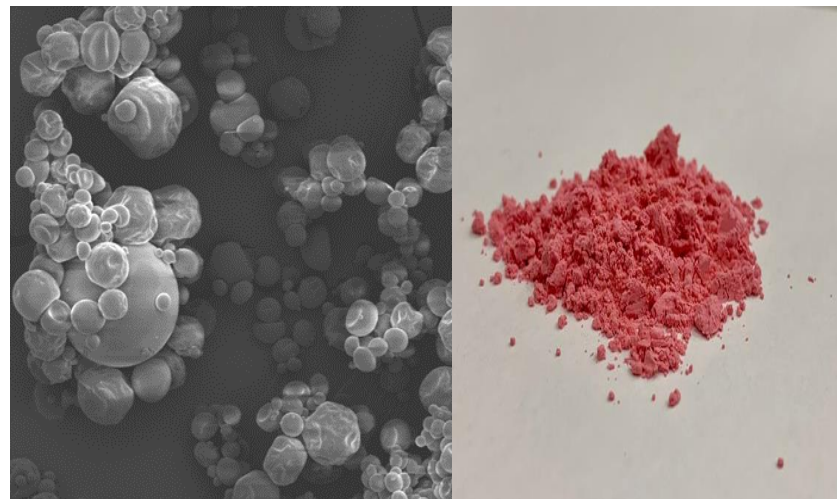

Project name: Developing Functional Foods for Healthy Aging based on secondary milk processing products. Functional Nutrition for active and healthy longevity (FuLife)



FUNCTIONAL NUTRITION
FOR ACTIVE AND HEALTHY LONGEVITY

Scientific adviser: Pavlova Anastasia, Ph.D.,

Development of a line of products of low-calorie, high-protein functional food for the prevention of alimentary-dependent diseases (cardiovascular diseases, diabetes mellitus, obesity, osteoporosis, some malignant neoplasms, etc.), the formation of a healthy lifestyle among citizens of the older generation:

- providing the opportunity to optimize the structure of nutrition and use specialized,
- fortified and functional foods to meet the needs of older people to consume high quality protein daily without increasing the proportion of simple carbohydrates in the diet.

Benefits:

- substantiation of the influence of functional nutrition on the health status of citizens of the older generation;
- conducting an environmental and economic assessment of the food line;
- using the “Engineering of Transition” approach to develop functional nutrition for older citizens.



Project name: Affordable WBC is the basis of population health

Scientific adviser: Baranov Alexander, D.Sc., abaranov@itmo.ru

General cryotherapy is a high-tech method of non-drug physiotherapeutic treatment of several serious diseases.



Benefits:

- development of resistance to seasonal epidemics, new viruses such as COVID-19;
- increase not only the duration, but also the quality of life of the population;
- decrease in the number of paid sick leave due to a decrease in the incidence of sickness in the population as a whole;
- an increase in the duration of the active period of life.

Project name: Affordable WBC is the basis of population health

The saturation of Russian clinics with cryotherapy devices has made general cryotherapy a relatively affordable procedure.

Project objective: the systematization and popularization of scientifically grounded recommendations for the selection of WBC technological parameters and the formation of a strict scientific concept for the design of specialized equipment

Characteristics:

- substantiation of the physical conditions for the manifestation of the therapeutic effects of WBC;
- the thermal challenge of cryogenic cooling of the WBC facility and the physical safety conditions of the WBC facility during procedures;
- physical and mathematical model of the WBC facility;
- software for the implementation of numerical experiments.

Projects:

- Deep processing of wheat to obtain bioethanol
- The use of ultrafine humato-sapropel suspensions in the fight against mycotoxins
- Development of technology for complex processing of residual brewer's yeast
- Development of Edible Food Coating for Cheese
- The role of biologically active substances of natural origin in the development and nutritional prevention of non-communicable diseases
- Development of a closed-cycle technology for chia seeds (*Salviahispanica* L.) as a functional food ingredient
- Obtaining secondary raw materials and energy resources based on the principles of circular economy



Customers and partners



Customers and partners





IX Международная научно-техническая конференция
«Низкотемпературные и пищевые технологии в XXI веке»

RU EN

[О конференции](#) [Требования](#) [Издания](#) [Новости](#) [Контакты](#) [Регистрация](#) [Вход](#)

X Международная научно-техническая конференция «Низкотемпературные и пищевые технологии в XXI веке». октябрь 2021 г.

[Регистрация >](#)

Food BioTech Conference 2021



August 23-25,

2021

Saint-Petersburg, Russia

Topics:

- **Biotechnology, Food and Nutrition**
- **Functional Foods and Preventive Medicine**
- **Food Quality, Safety and Society**
- **Food Processing and Process Control**
- **Sustainable Consumption and Production**

FOOD BIOTECH Conference

August 23-25, 2021

St. Petersburg, Russia



Welcome to the international Food BioTech Conference 2021!

The Conference is hosted by the School of Biotechnology and Cryogenic Systems of ITMO University, and will be held on August 23-25, 2021 in St. Petersburg, Russia. The event will be held in a blended format combining online and offline modes. The official language of the event is English.

The Conference has already attracted world-famous scientists, and we hope that you will join this prestigious international event on Food Biotechnologies in Russia.

Find out more on <https://foodbiotech.itmo.ru/>



Conference website



Facebook



Twitter

OUR PLENARY SPEAKERS



Da-Wen Sun
(Ireland)
University College Dublin



Denis Baranenko
(Russia)
ITMO University



Chin-Kun Wang
(Taiwan)
Chung Shan Medical University



Marco Dalla Rosa
(Italy)
Università di Bologna



Pedro A. Garcia Encina
(Spain)
University of Valladolid

The Conference is an excellent opportunity to share your academic and clinical research and find new scientific and industrial partners in several fields:

- Biotechnology, Food and Nutrition
- Functional Foods and Preventive Medicine
- Food Quality, Safety and Society
- Food Processing and Process Control
- Sustainable Consumption and Production

Submit your abstract before May 1, 2021.

Early-bird registration is available until April 30, 2021.

foodbiotech.support@itmo.ru



ITMO UNIVERSITY

Thank you for your attention!
rumiantseva@itmo.ru