

Direct electric heating of concrete mixture as energy-efficient approach of accelerated curing

M.I. Batyuk¹, A.I. Gnyrya², S.V. Korobkov², V.Ya., Ushakov¹,

¹National Research Tomsk Polytechnic University

²Tomsk State University of Architecture and Building

Accelerated curing methods widespread in Russia

- Steam curing **Efficiency 20-30 %**
- Accelerated
curing in gas
combustion
products **Efficiency 20-40 %**

Direct electric heating methods

- Direct electric curing
- Forced direct electric heating of concrete
- Preliminary direct electric heating (preheating) of concrete mixture

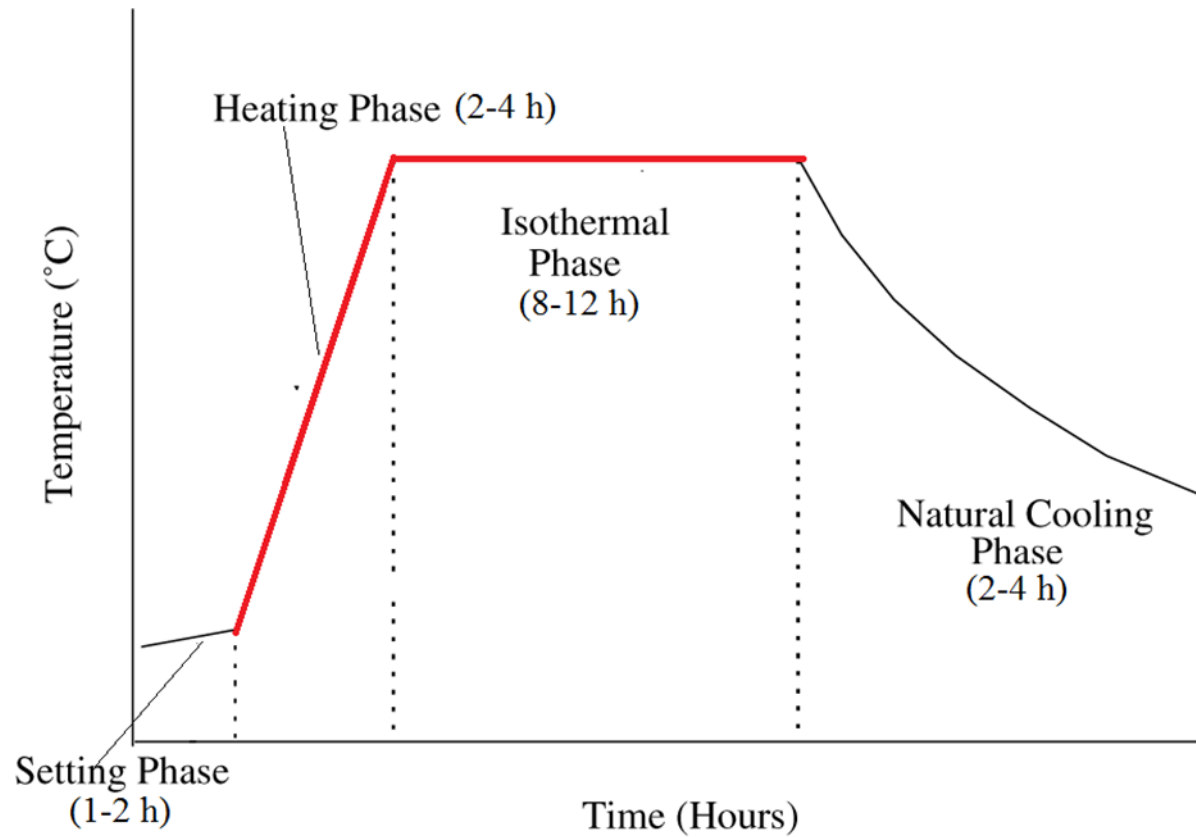

General form of temperature curve used with accelerated curing techniques.

The purpose of experiments

- Heat concrete to a temperature of 50, 60 and 70 °C in 10 minutes, disconnect from power source and insulate
- Study the dynamics of temperature change and distribution
- Evaluate the effect of temperature conditions on strength and energy consumption

Equipment

- Polyamide mold with steel electrodes and plates for forming three samples with dimensions of 100 x 100 x 100 mm
- Power supply, energy meter, amperemeter, voltmeter, PID-controller, relays
- Temperature sensors, DAQ system, PC.

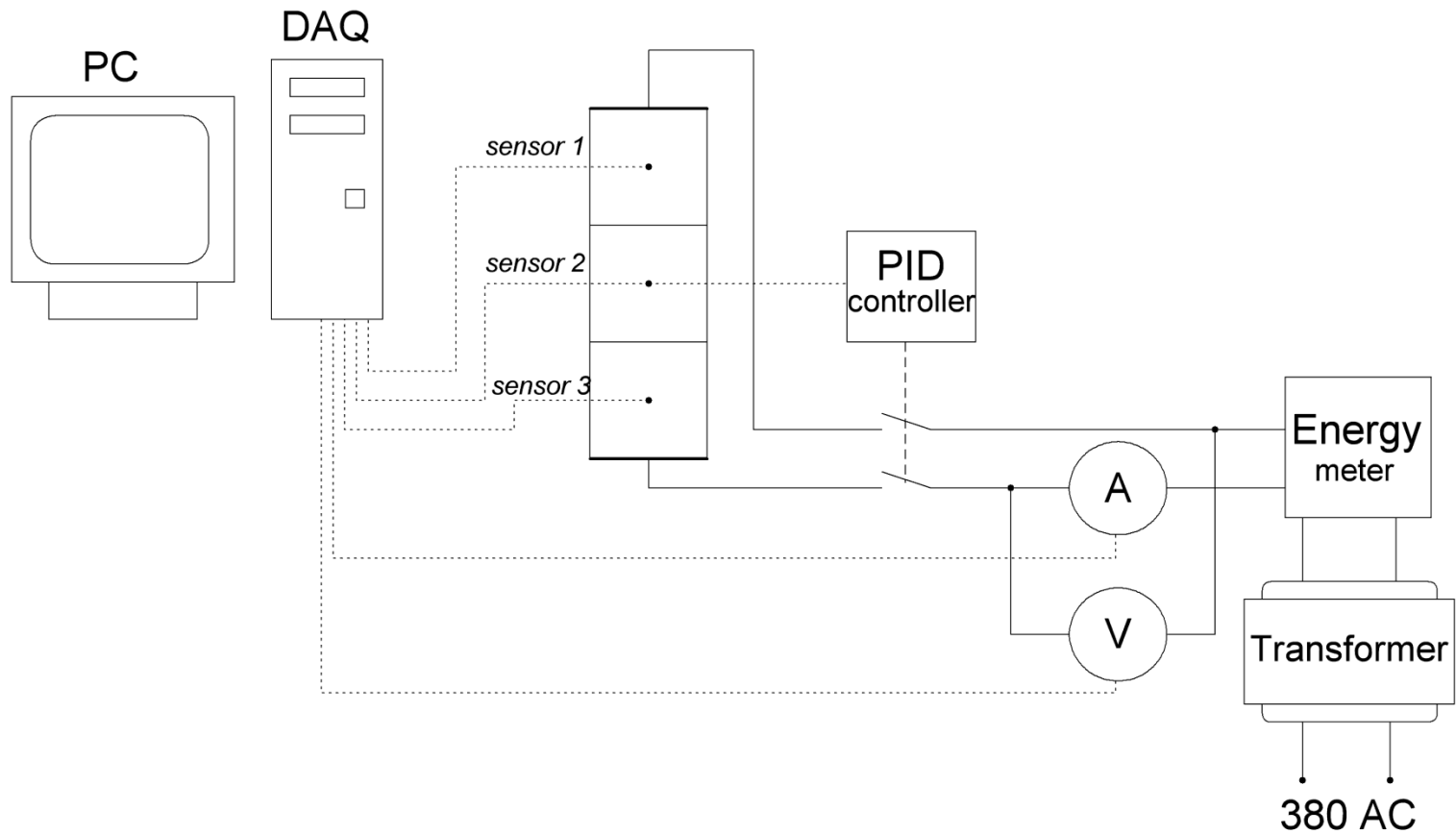

Experiment scheme

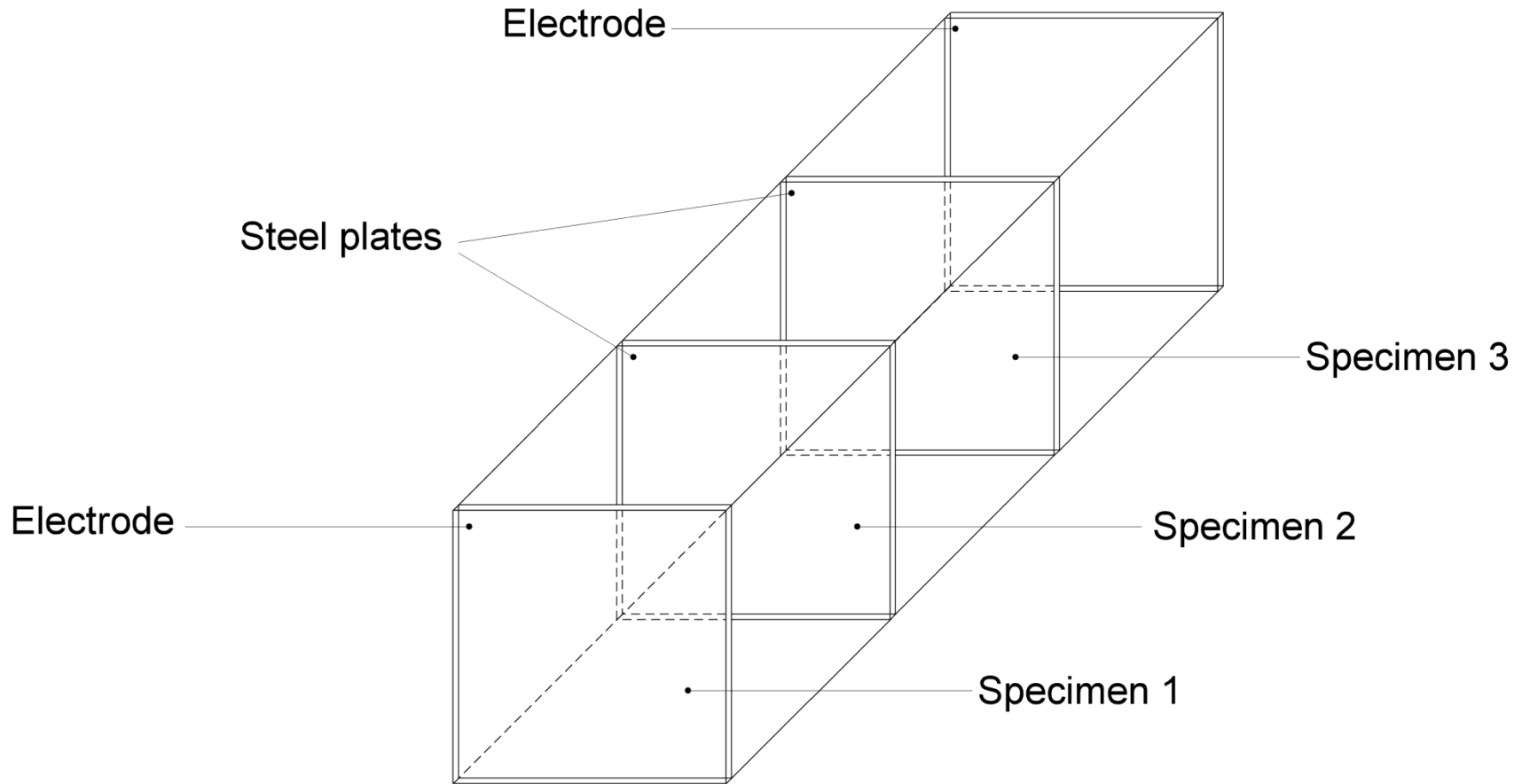

Design of mold

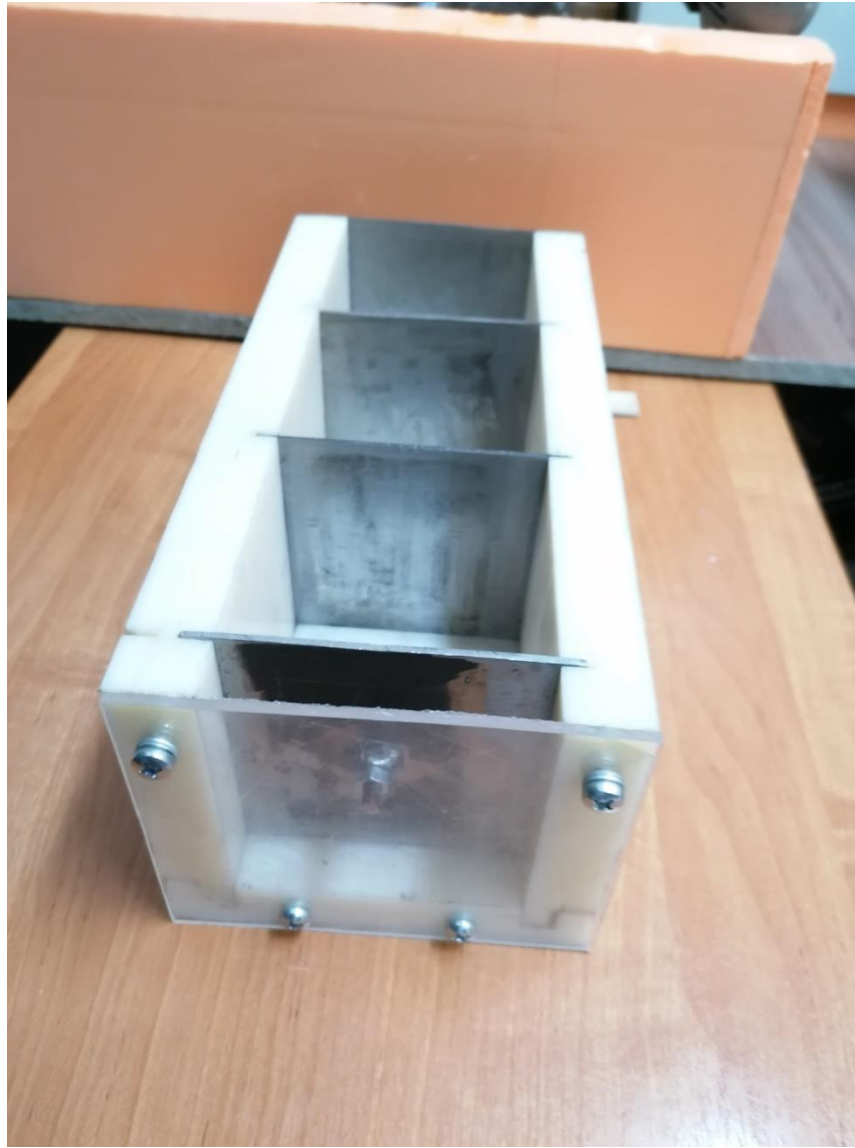

The mold



Cover for insulating the mold

Mixture composition

Component	Type	Content (kg/m ³)
Cement	ЦЕМИ 42,5 Б	350
Sand	2-2,5 mm	810
Gravel	5-20 mm	1100
Water	-	158



Heating of fresh concrete

Variation and distribution of temperature when concrete is heated to 50 °C

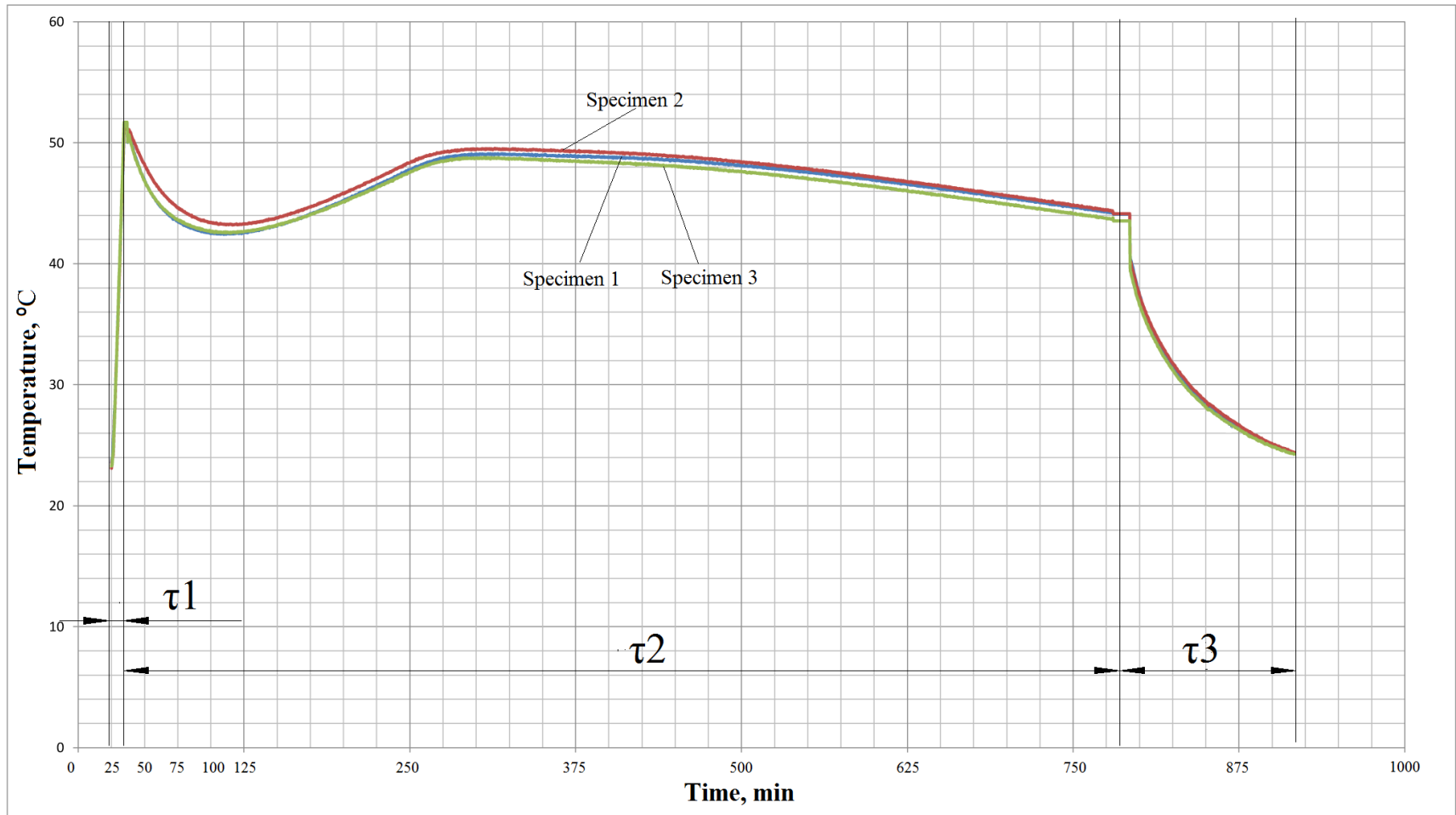

τ_1 – Heating phase (10 min.); τ_2 – Isothermal phase without additional heat source (13 h.),
 τ_3 – natural cooling phase (3 h.)

Average temperature variation of specimens heated to 50, 60 and 70 °C

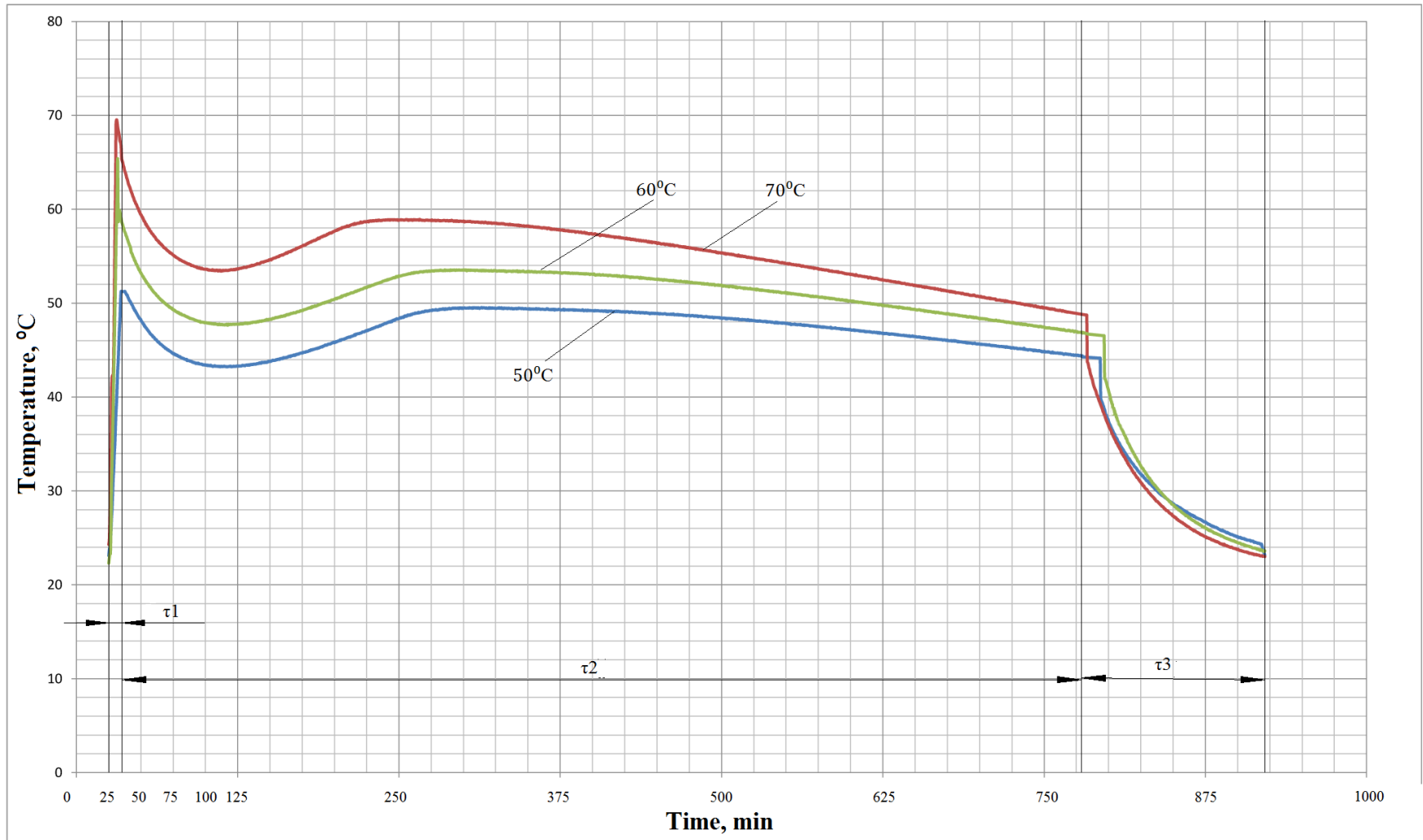

τ_1 – Heating phase (10 min.); **τ_2** – Isothermal phase without additional heat source (13 h.),
 τ_3 – natural cooling phase (3 h.)



Samples after insulation removing



Samples after demolding. Natural cooling phase.

Data for experiment

Experiment maximum temperature, °C	50	60	70
Energy supplied (kWh)	0,07	0,1	0,13
Average compressive strength, MPa	28,83	30,06	31,97
Percentage of expected strength, %	88	92	96

Thanks for attention!