

Title: Simulation modeling of metallurgical flowsheet for processing raw materials

Authors: Azamat Ipmagambetov¹

Co-authors: Marzhan Sadenova¹, Petar Varbanov²

**Affiliations: Priority Department Centre «Veritas», D. Serikbayev East
Kazakhstan Technical University¹**

Brno University of Technology, FME, NETME Centre, SPIL²

Simulation modeling of metallurgical flowsheet for processing raw materials

Names: Azamat Ipmagambetov, Marzhan Sadenova, Petar Varbanov

Affiliations: Priority Department Centre «Veritas», D. Serikbayev East Kazakhstan Technical University

Keywords:

Simulation, modeling, metallurgical, raw

Research Objective:

The problem of increasing the resource productivity of mining and metallurgical production and the environment is gaining great importance throughout the world, due to the level of resource scarcity as the available sources are exhausted. Also, you can use the tendency to improve the formation of technogenic waste as a result of the deterioration of the technological quality of ores and a significant lag in mining and metallurgical processing technologies from the changing characteristics of the raw material base.

The introduction of a system of simulation modeling of metallurgical resource schemes is one of the most promising ways to solve the problem. Such a tool allows you to apply and analyze possible “what if” scenarios, for example, to apply the effect of the development of raw materials entering processing without compromising the production process and to assess the degree of risk and find the most reliable solutions before making real changes to the processing scheme. Virtual experiments with simulation models are cheaper and less time-consuming than experiments with real process flow diagrams.

Simulation modeling of metallurgical flowsheet for processing raw materials

Names: Azamat Ipmagambetov, Marzhan Sadenova, Petar Varbanov

Affiliations: Priority Department Centre «Veritas», D. Serikbayev East Kazakhstan Technical University

Keywords:

Simulation, modeling, metallurgical, raw

Individual components of the simulation model

Program for mass and thermal balance of technological schemes

Thermochemical database

Gibbs energy minimizer

Data interface

The purpose of the simulation model - is to calculate the material and heat balances of processes, taking into account the mutual influence of intermediate products from one redistribution of the technological scheme for processing lead raw materials on the processes of another.

Application: Forecasting the annual and monthly balances of heavy non-ferrous metals, fluxes, reagents and fuels; Analysis of the possibility of a particular new type of raw material being triggered, based on the distribution of the main and minor elements by redistribution, and their negative impact on the processes, which consists in the loss of the base metal in the recycled products, for example, cakes, slags, slip, melts, etc.

Simulation modeling of metallurgical flowsheet for processing raw materials

Names: Azamat Ipmagambetov, Marzhan Sadenova, Petar Varbanov

Affiliations: Priority Department Centre «Veritas», D. Serikbayev East Kazakhstan Technical University

Keywords:

Simulation, modeling, metallurgical, raw

The model is built in several stages:



data collection for the model developer



model building by the developer



testing the configuration of the model together with technologists



adjustment of the model according to the remarks of the technologists



statistical analysis of the model



model acceptance

Simulation modeling of metallurgical flowsheet for processing raw materials

Names: Azamat Ipmagambetov, Marzhan Sadenova, Petar Varbanov

Affiliations: Priority Department Centre «Veritas», D. Serikbayev East Kazakhstan Technical University

Keywords:

Simulation, modeling, metallurgical, raw

Building a simulation model in a predictive mode

Pyrometallurgical units are modeled in the FactSage program, which has 3 elements: interface + Gibbs energy minimizer + thermodynamic database; Due to the fact that the FactSage program cannot be directly connected with SysCAD, the ChemApp intermediate program is used, which consists of one element - the Gibbs energy minimizer, which, using the FactSage thermodynamic model, makes calculations inside SysCAD; At the same time, in the course of building models in FactSage, it is possible to select databases. To a rough approximation, databases can be divided into public and custom databases. At the same time, a customized database for lead and copper production is more accurate, since it was worked out specifically for these industries by scientists;

Hydrometallurgical units are modeled directly in the SysCAD program; At the same time, the reactions and the completeness of the course of reactions are prescribed on the basis of technological regulations and discussions with technologists.

Simulation modeling of metallurgical flowsheet for processing raw materials

Names: Azamat Ipmagambetov, Marzhan Sadenova, Petar Varbanov

Keywords:

Affiliations: Priority Department Centre «Veritas», D. Serikbayev East Kazakhstan Technical University

Simulation, modeling, metallurgical, raw

An overview of the logic of building a SysCAD model of one processing on the example of an ISA furnace

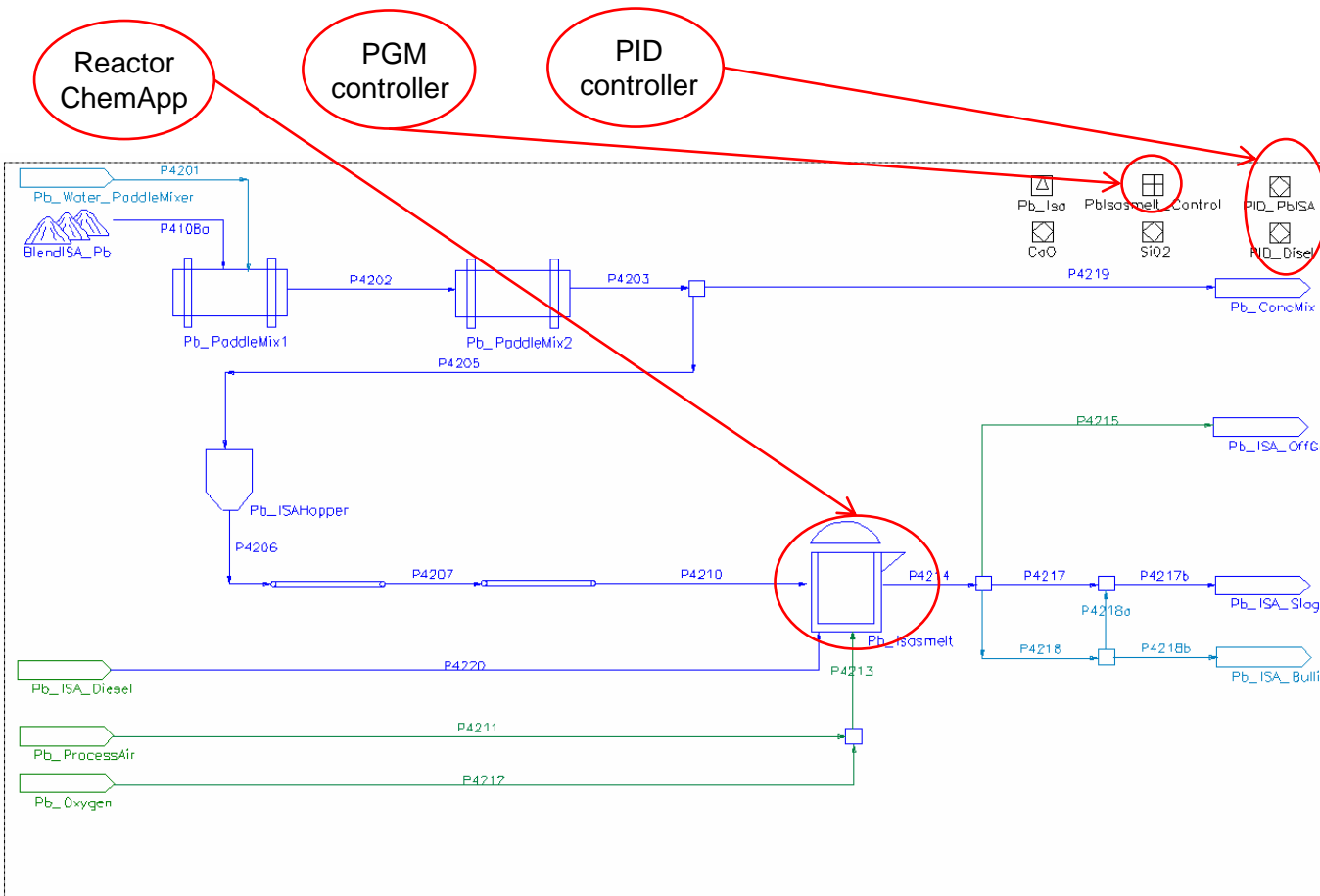

ChemApp Reactor - allows you to run a FactSage model inside a SysCAD flow chart.

PID controller - makes it possible to calculate the load of an input stream depending on a target process indicator.

PGM controller - you can register all the same functions that the PID controller has using coding, and much more. In the models, the main functions of the PGM codes are to calculate the mineralogical composition, mix concentrates, and indicate process control targets.

Simulation modeling of metallurgical flowsheet for processing raw materials

Names: Azamat Ipmagambetov, Marzhan Sadenova, Petar Varbanov

Keywords:

Affiliations: Priority Department Centre «Veritas», D. Serikbayev East Kazakhstan Technical University

Simulation, modeling, metallurgical, raw

Key assumptions when building a model

№	Assumption	Negative effect	Solutions
1	<p>The material and heat balances of the processes are calculated based on the mineralogical compositions of the incoming flows. In this case, the mineralogical composition of each individual stream is calculated from its actual elemental composition. In this case, neither the elemental composition nor the mineralogical composition of the streams at the inlet is 100% summed up. In this connection, the missing difference is defined as “inert material”, which is distributed in proportion to the yield of the products of the process.</p>	<p>The lack of full knowledge about the material composition of incoming flows negatively affects the results of thermodynamic models and, accordingly, the material and heat balances of the processes.</p>	<p>Obtaining more reliable data on the mineralogical composition of raw materials, industrial products and manufactured products</p>

Simulation modeling of metallurgical flowsheet for processing raw materials

Names: Azamat Ipmagambetov, Marzhan Sadenova, Petar Varbanov

Keywords:

Affiliations: Priority Department Centre «Veritas», D. Serikbayev East Kazakhstan Technical University

Simulation, modeling, metallurgical, raw

Key assumptions when building a model

№	Assumption	Negative effect	Solutions
2	<p>Dust. In order to take into account in the dust of pyrometallurgical aggregates and mechanical dust removal and chemically ignited and precipitated particles, the following approach was used: to capture the ignited dust from the dust-gas mixture coming from the furnace, FactSage models are used, based on the deposition of particles with a decrease in temperature, while the target content and the amount of dust (according to actual data) and the missing difference (mechanical dust removal) is extracted from someone's intermediate or input stream.</p>	<p>The content and volume of dust will be fully regulated by the balancer, i.e. it is no longer quite predictive modeling.</p>	<p>When using (improving) the work of the customized database, the distribution of all components in the dust-gas mixture, as well as the deposition of dust particles with a decrease in temperature, will be more accurate. In this case, it will not be necessary to remove the excess of any component, but only there will be a need to set (manual input) the percentage of mechanical dust removal. In this case, it will be possible to predict the composition and volume of dust from pyrometallurgical units. At the same time, the composition and volume of aspiration gases will remain manually entered (according to historical data).</p>

Simulation modeling of metallurgical flowsheet for processing raw materials

Names: Azamat Ipmagambetov, Marzhan Sadenova, Petar Varbanov

Keywords:

Affiliations: Priority Department Centre «Veritas», D. Serikbayev East Kazakhstan Technical University

Simulation, modeling, metallurgical, raw

Key assumptions when building a model

No	Assumption	Negative effect	Solutions
3	The loading of fluxes (reagents) affecting the chemistry of the process is calculated depending on the target indicators of the process. If these reagents, fluxes are not assigned to any target indicator, then these reagents are taken from the norms and limits of the shops (practical data).	The thermodynamic calculation does not take into account the influence of kinetic factors, and therefore the estimated consumption of any flux may be underestimated or overestimated. When using norms (based on current limits and norms), there is a risk of lack of control over the process, since different batch will behave differently and in this case, a correctly performed calculation will show the need to increase / decrease the loading of reagents.	In this case, when building, testing and using the model, it is necessary to constantly check the calculated data with the established norms and limits. It is possible to prescribe regulations for the periodic verification of calculations with the norms.

Conclusions

Reducing the consumption of fluxes by 5% and reagents by 10% at the stage of processing lead raw materials at the ISA furnace by increasing the degree of control over the behavior of the target ratio of CaO / SiO₂ and SiO₂ / Fe + Zn in the slag, affecting the consumption of process oxygen and diesel fuel.

References

<https://www.factsage.com/>

<https://www.syscad.net/>

<https://gtt-technologies.de/software/chemapp/>

Simulation modeling of metallurgical flowsheet for processing raw materials

Names: Azamat Ipmagambetov, Marzhan Sadenova, Petar Varbanov

Affiliations: Priority Department Centre «Veritas», D. Serikbayev East Kazakhstan Technical University

Keywords:

Simulation, modeling, metallurgical, raw

Thank you for your attention!

Authors: *Azamat Ipmagambetov*¹

Co-authors: *Marzhan Sadenova*¹, *Petar Varbanov*²

Affiliations: *Priority Department Centre «Veritas», D. Serikbayev East Kazakhstan Technical University*¹;

*Brno University of Technology, FME, NETME Centre, SPIL*²

Contact details: *Petar Varbanov*, <varbanov@fme.vutbr.cz>;

Azamat Ipmagambetov, <ipmagambetov@gmail.com>;

Marzhan Sadenova, <MSadenova@ektu.kz>